

› INCORPORATING RODA

ANDAX

Automatic Partition Assembler
(corrugated board partitions)



SOLEMA

LONGITUDINAL ELEMENTS PROCESSING



Longitudinal elements have to be fed vertically onto the conveyor belt, inside the guiding channels. The standard machine is endowed with 6 guiding channels. The feeding operation of 6 channels can be done by hand or by means of **DUPLEX** (optional).

CROSS ELEMENTS FEEDING



Cross dividers feeder is built on the top of the interlocking area, in the middle of the machine. The elements are kept upright by a pressure system and moved to the injection area by means of belts.

DUPLEX (optional)

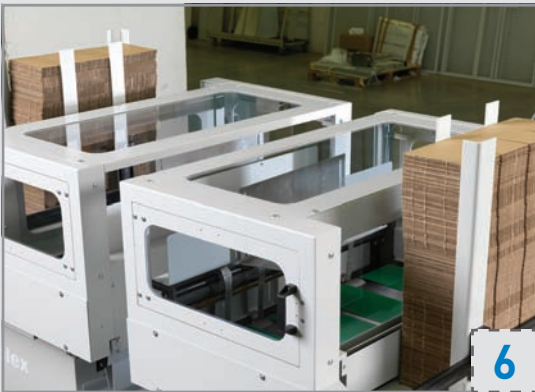

To load the longitudinal elements into the guiding channel, machine can be endowed with automatic feeders to feed the elements out of a special hopper where elements are stacked. **DUPLEX** feeder can be placed on the right and/or left of the machine's main belt. Each **DUPLEX** can feed max. 3 guiding channels.

COLLAPSER (optional)



After assembly, partitions can be collapsed (automatically folded flat), counted and divided into batches and delivered onto a delivery table ready to be packed by means of the **COLLAPSER** automatic delivery device (optional).

ANDAX is a very robust and versatile machine designed for the automatic assembly of corrugated board partitions.

It can handle all types of corrugated board, from E-flute to double wall including microflute and twin dual, with maximum consistency and productivity.

The machine is manufactured from **SOLEMA** and integrate the best of the 70 years **RODA** technology and expertise in construction of highly reliable assembly machines.

Relatively small footprint of **ANDAX** allows its application even in very narrow places.

ANDAX is endowed with a PLC with touch screen interface for job settings and to enable the possibility of saving all parameters of specific product to be recalled in case of a repetitive work, minimizing machine's set up time.

Production rates up to max. 50 partition sets/minute (depending on partitions dimensions) and is delivered in standard configuration with six longitudinal channels and the possibility of inserting up to twenty four cross elements.

For an optimized running speed and productivity the machine can be optionally supplied with:

- **Duplex** feeders: automatic feed of longitudinal elements (up to six channels fed automatically)
- **Collapser**: automatic folding, counting and batching of assembled partition on a delivery table

INTERLOCKING OF ELEMENTS

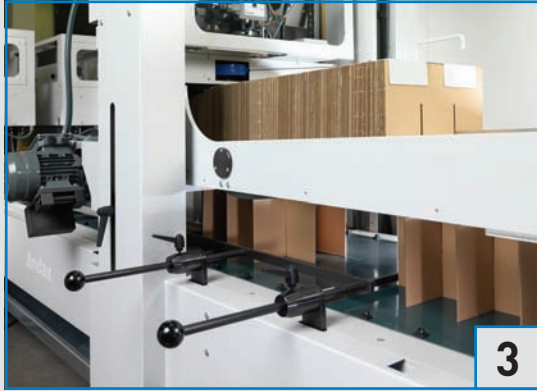

Once the longitudinal elements reaches the correct position, they are detected from a photocell which activates the short stroke piston that pushes cross elements through 2 high speed running rollers to ensure a precise penetration of cross elements through the longitudinal ones.

TOUCH SCREEN / ELECTRICAL CABINET



The machine is controlled and operated from the touch screen panel installed on electrical cabinet. From this HMI the operator processes and save data related to the different partitions like: number of cuts in longitudinal element, motors speed, injection timing, etc

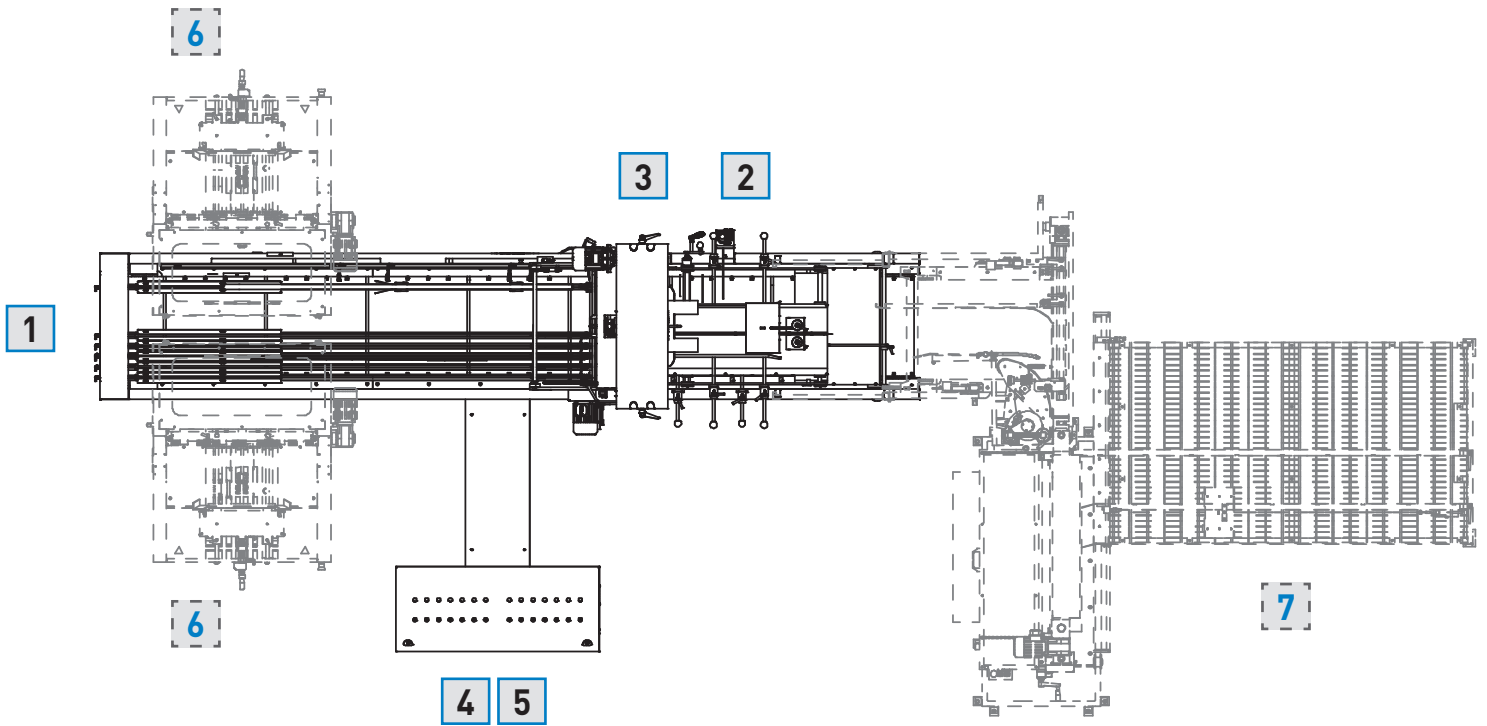

ANDAX

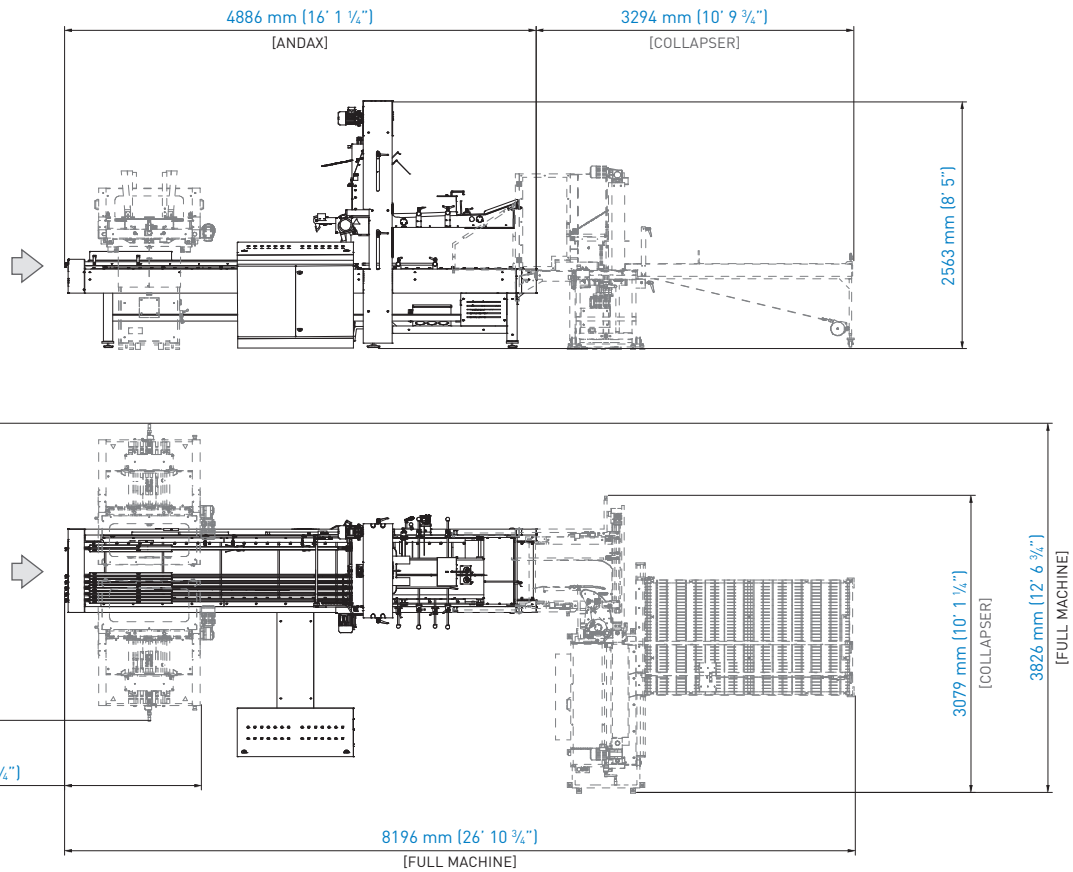

■ total weight with optional units approx. 3370 kg (7,430 lb)

TECHNICAL DETAILS

PRODUCTS

- E — BC flutes, min. 1.6 mm (5/128")

SPEED

- max. 50 partitions/minute

MAIN BELT SPEED

- min. 5,4 m/minute (17 ft/minute) — max. 32,5 m/minute (106 ft/minute)

CHANNELS FOR LONGITUDINAL ELEMENTS

- automatic version: 6
- manual version: 8

TRANSVERSAL ELEMENTS INJECTIONS

- standard version: 24

LONGITUDINAL ELEMENTS LENGTH (A)

- automatic version: max. 850 mm (33 7/16")
- manual version: max. 1150 mm (45 3/32")

TRASVERSAL ELEMENTS LENGTH (B)

- max. 540 mm (21 17/64")

PARTITION'S HEIGHT (C)

- min. 50 mm (1 31/32") — max. 400 mm (15 3/4")

CELL DIMENSIONS (D — E)

- (D) min. 35 mm (1 3/8")
- (E) min. 15 mm (19/32")

COLLECTION TABLE COLLAPSER

- max. bended partition length 1150 mm (45 3/32")

ELECTRICAL REQUIREMENTS

- electrical power supply: 3 × 400 V PE 50 Hz
- controls voltage: 24 V DC

PNEUMATIC SYSTEM

- pressure: 6 bar

OPTIONAL DEVICES AVAILABLE

- DUPLIX Feeders
- COLLAPSER folder

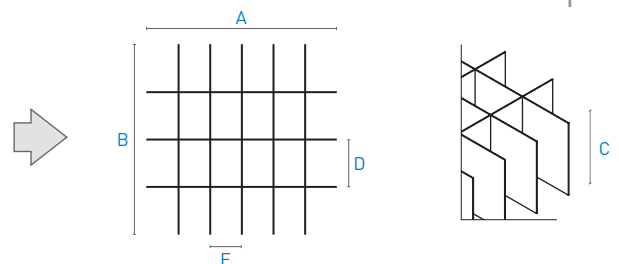

> PERFORMANCES DEPEND ON PRODUCT'S SIZES, PRODUCT'S QUALITY AND OPERATING CONDITIONS

SOLEMA

Via Carducci, 18 — 24066 Pedrengo — Bergamo • Italy
 Tel. +39 035 654111 • Fax +39 035 654112
 e-mail: info@solema-boards.com • web: www.solema-boards.com

FOR NORTH AMERICA

Solema USA inc

315 Glenn Street - P.O. Box 472
 Crawfordsville - IN - 47933
 USA

info@solemausa.com
 tel. 765 361 0806 / fax 765 361 0989