

› INCORPORATING RODA

MULTIROLL-CUT

Pads and Partitions in Solid Board

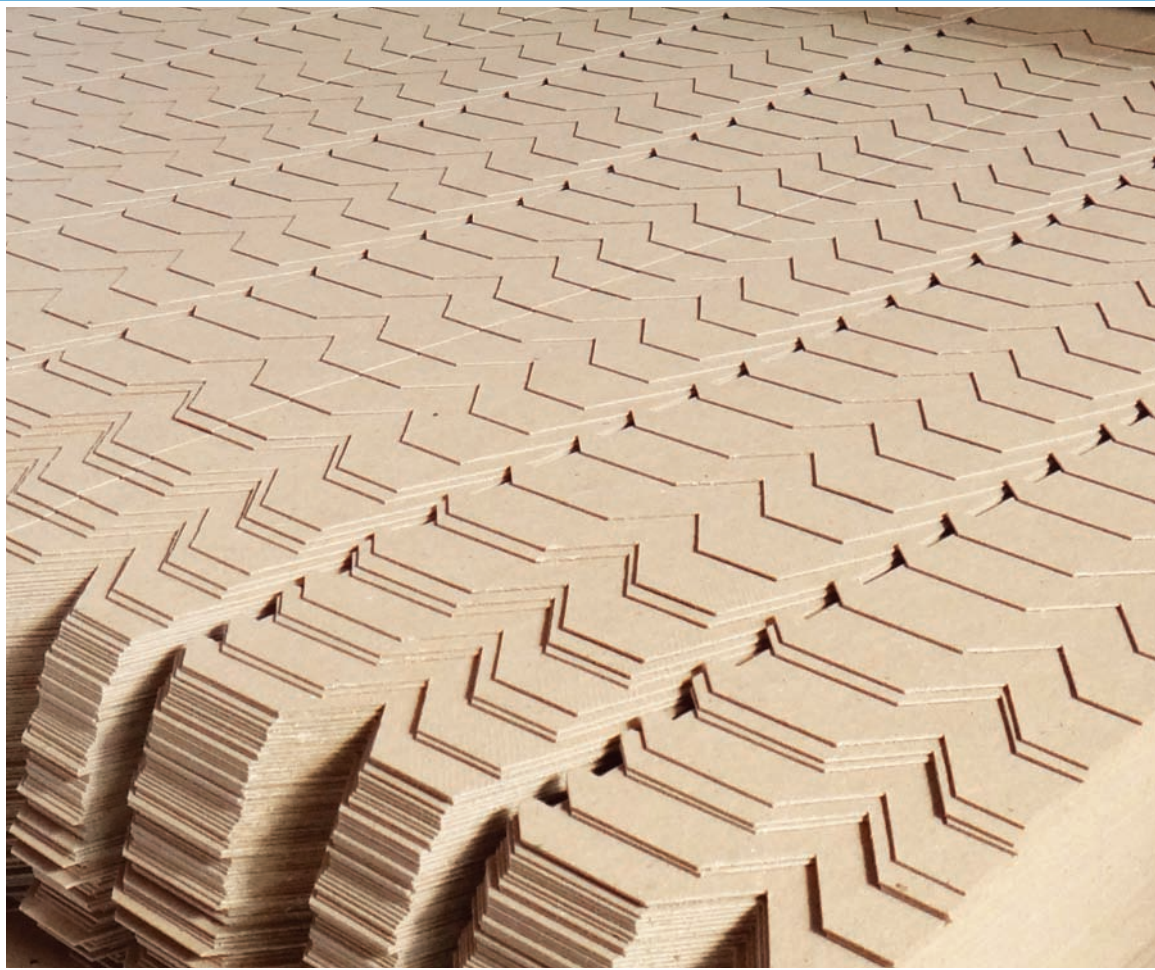

SOLEMA

UNWINDING UNIT WITH CHUCKS

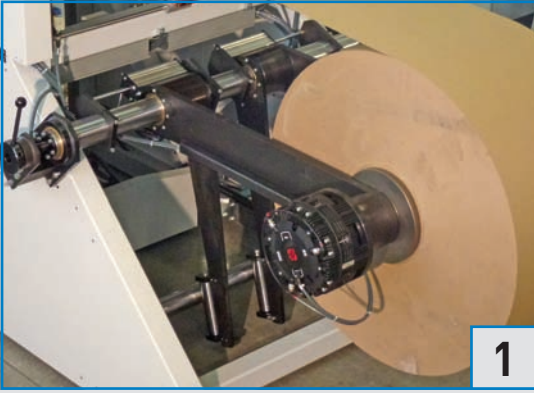

For an easier reel's loading / unloading, the unwinding unit is equipped with two lifting chucks. To be placed between the chucks, the reel is unwinded through a group of pulling rolls; another series of rollers assure the proper board's tension, removing any curves on the board. Changing the pulling torque, brakes allow to modify the board tension, bring it to the desired value.

LATERAL WASTE TRIMS AND BUFFER

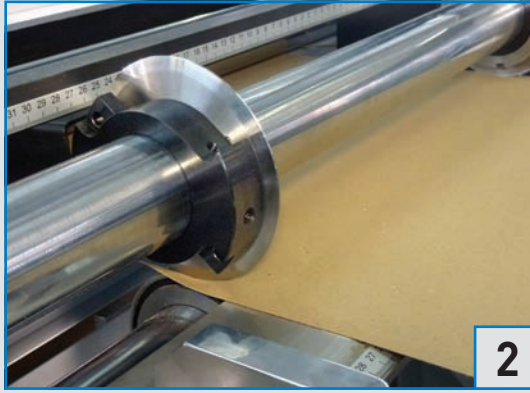

Out of the unwinding unit, two rotary knives cut the lateral waste trims of the reel. Following, a photocell located after the knives stops the reel's unrolling when a certain stock is reached (board's buffer) and then it starts again when the buffer is exhausted.

CROSS CUTTING BLADES



The stripes which come from the slitting section are cut into the actual division by a pair of cross cutting blades. The cross cutting knives guarantee a neat and high quality cut, avoiding any imperfection on the pieces.

TOUCH SCREEN

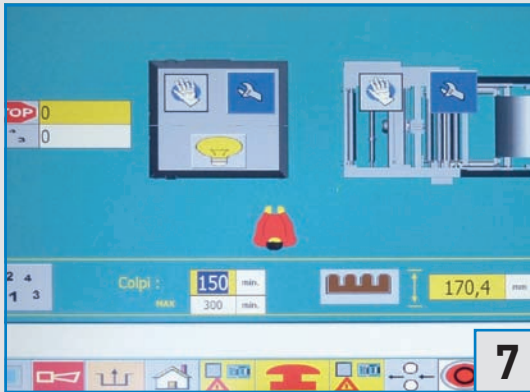

Touch screen of the latest generation, located close to the machine (position can be discussed), allows to control the machine easily.

Designed for accurate, high speed production of solid fiber partitions, pads and strips directly from the reel.

MULTIROLL-CUT is a completely automatic Die-Cutting machine, equipped of latest technology (PLC Siemens and touch screen).

Continuous unwinding, with no need of adjustments thank to the photocells device, makes paperboard flow easy to manage avoiding corrective interventions from operator.

Only one operator is need for the size change and collection of finished products.

A large variety of Die-Cutting tools are available offering the customer the possibility to customize partition's shape as per their preference.

FINISHED PRODUCT

- STRIPES
- PADS / PROTECTIVE PADS
- PARTITION'S ELEMENTS
- 'U' ELEMENTS

DIE-CUTTING UNIT

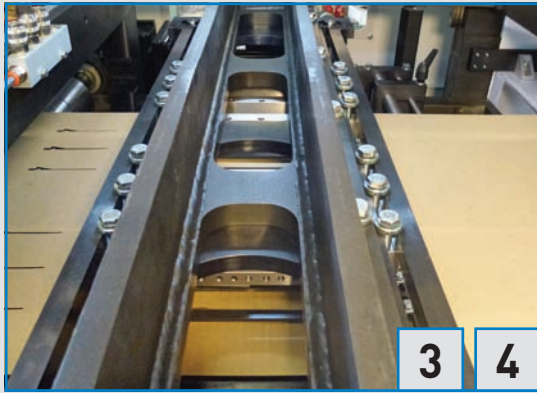

The stripe of board, coming from the un-winder, is driven by adjustable advancement rollers into the Die-Cutting section. The board is cut by tools (male-female) installed on a robust cross bar. The scraps produced during the operation are removed by a waste conveyor, installed under the machine.

COLLECTING CONVEYOR

The cut pieces are orderly shingled out onto the collecting table. A roller system, in front of the table, allows a proper positioning of the pieces. Thank various setting present on the machine the operator can choose to work with continuous or of bundled cut pieces.

8

SLITTING SECTION

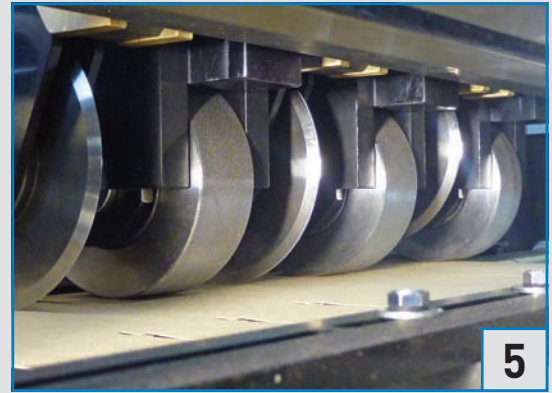

Soon after the Die-Cutting, three pair of rotary knives execute a precise longitudinal cut. Additional knives can be installed upon customer's request, as an option.

PRINTING DEVICE

A special equipment allows to print logos, references on the material to be cut giving the possibility to customize own products.

9

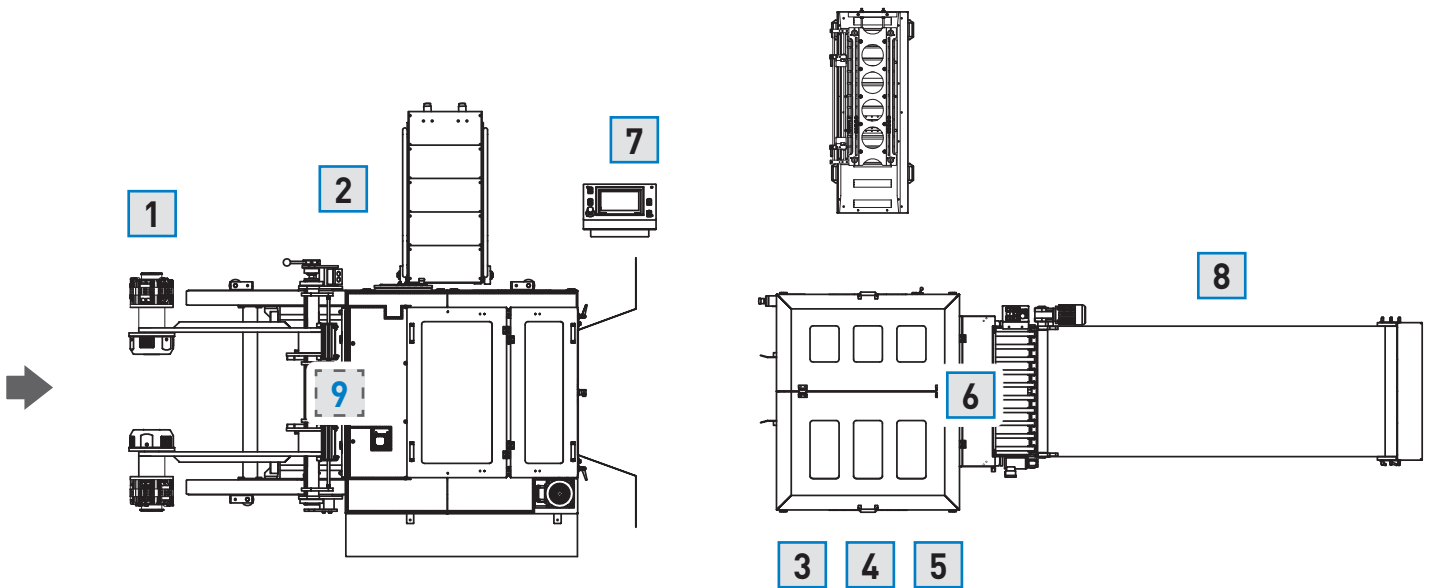

MULTIROLL-CUT

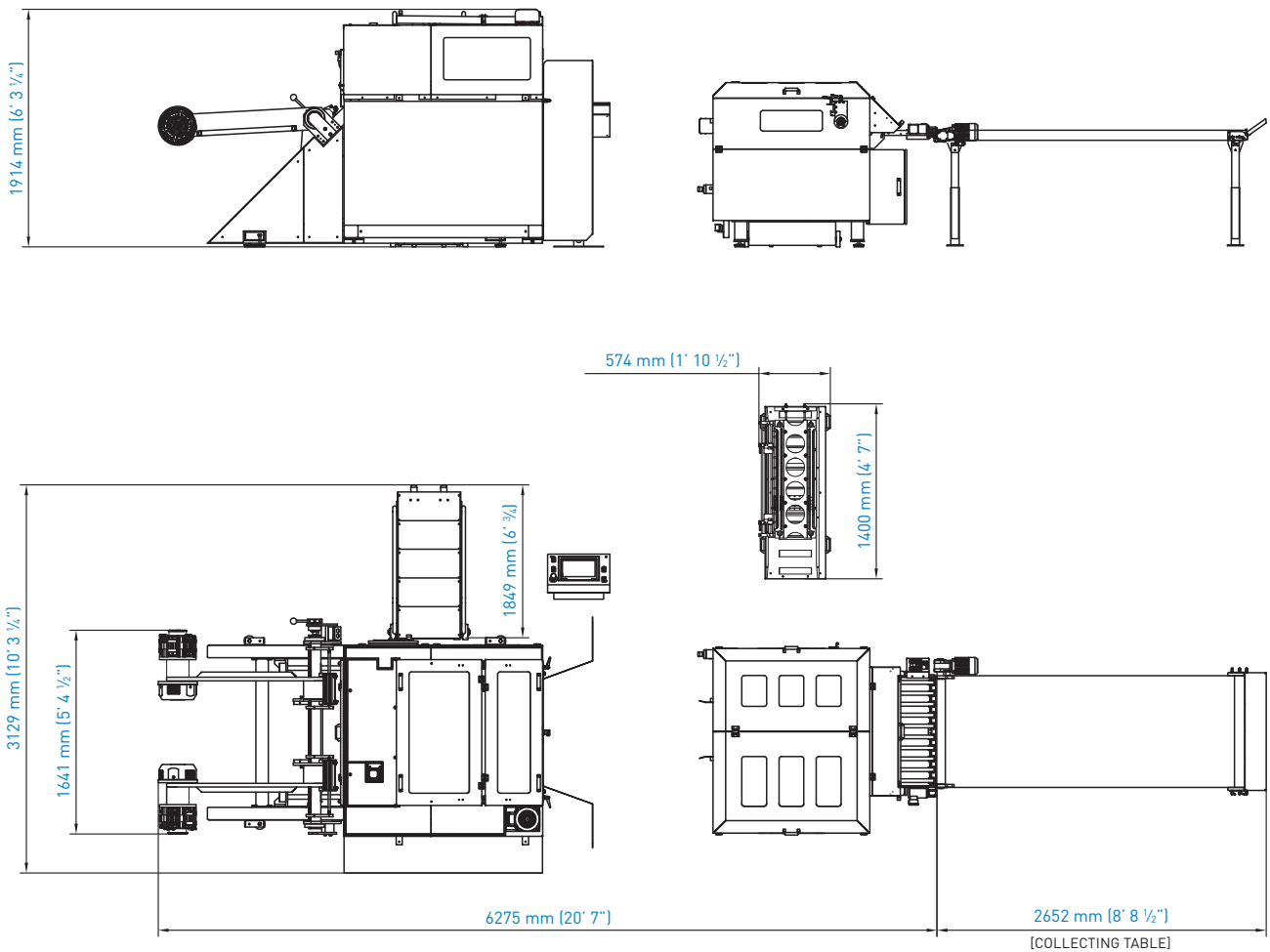

■ weight without reel approx. 3200 Kg (7054 lb)

TECHNICAL DETAILS

UNWINDING UNIT

- reel width:
min. 100 mm (3 9/16") — max. 850 mm (33 39/64")
- reel diameter:
max. 2000 mm (78 47/64")
- reel core diameter:
150 mm (5 7/8") — 200 mm (7 7/8") — 300 mm (11 13/16")
- board thickness:
min. 0.5 mm (3/128") — max. 1.2 mm (6/128")
- reel weight:
max. 1500 kg (3307 lb)

BLANK UNIT

- cutting length:
min. 10 mm (25/64") — max. 500 mm (19 44/64")

FINISHED DIE-CUT PRODUCT

- height:
min. 38 mm (1 32/64") — max. 400 mm (15 48/64")

- width:
max. 810 mm (31 37/64")
- space between die-cuts:
min. 20 mm (50/64")
- cutting rate:
max. 300 cuts/minute

ELECTRICAL REQUIREMENTS

- electrical power supply: 3 × 400 V PE 50 Hz
- controls voltage: 24 V DC

PNEUMATIC SYSTEM

- pressure: 6 bar

OPTIONAL DEVICES AVAILABLE

- PRINTING DEVICE
- WASTE CONVEYOR