

› INCORPORATING RODA

# SB-FEED

## Automatic Sheets Feeder



SB-FEED allows optimum performances and set free the operator. Equipped with a stack elevator and vacuum head, the top sheet is automatically transported via a set of transfer rolls to pre-feed position, on the infeed table.

A timed pusher and squaring device, then automatically introduces the sheet into the machine at the correct moment.

Pallets with material's sheets can easily be positioned on the stack elevator by means of manual or

electric fork lifts. SB-FEED is endowed with a self standing electrical cabinet to allow retrofitting on existing machines.

Fast and precise inserting of solid fiber board, padded, acetate, foam and plastic materials.

## SB-FEED

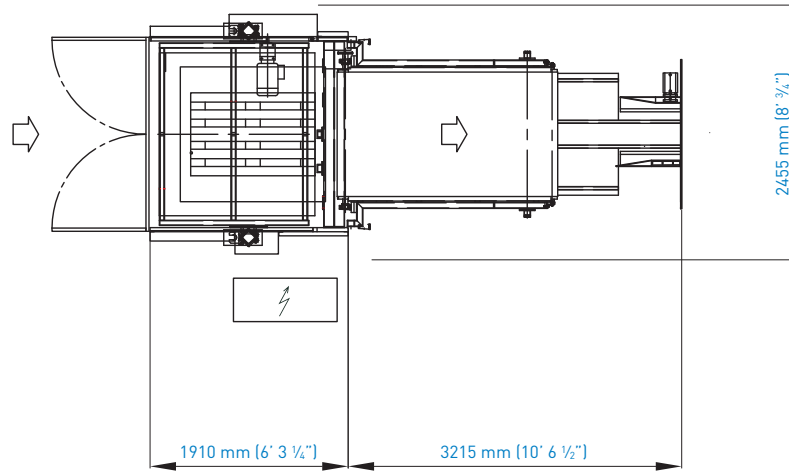
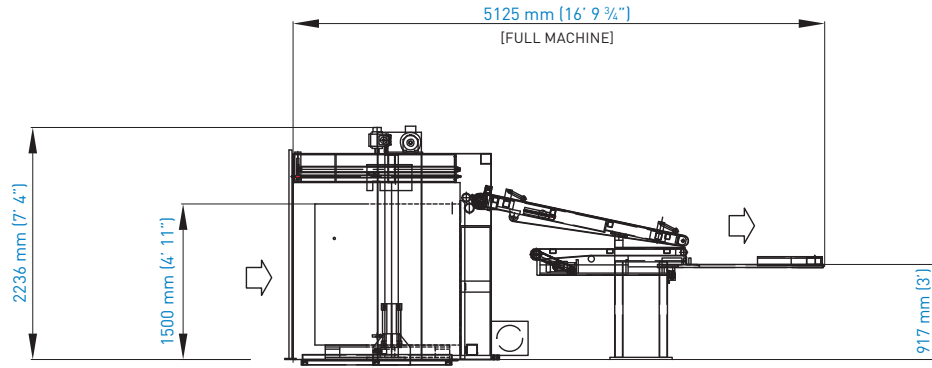

■ total weight approx. 2000 kg (4409 lb)

## TECHNICAL DETAILS

### SHEETS LENGTH

- min. 600 mm (23 <sup>40</sup>/<sub>64</sub>"") — max. 1400 mm (55 <sup>8</sup>/<sub>64</sub>"")

### SHEETS WIDTH

- min. 500 mm (19 <sup>44</sup>/<sub>64</sub>"") — max. 1300 mm (51 <sup>12</sup>/<sub>64</sub>"")

### PILE HEIGHT

- max. 1500 mm (59 <sup>4</sup>/<sub>64</sub>"")

### PILE WEIGHT

- max. 1800 kg (3968 lb)

### SOLID BOARD THICKNESS

- min. 0.75 mm (<sup>4</sup>/<sub>128</sub>"") — max. 4 mm (<sup>10</sup>/<sub>64</sub>"")

### SPEED

- max. 2400 sheets/hour with small format sheets

### ELECTRICAL REQUIREMENTS

- electrical power supply: 3 × 400 V PE 50 Hz
- controls voltage: 24 V DC

### PNEUMATIC SYSTEM

- pressure: 6 bar

### APPLIES TO

- IDEALGANDRIA
- GANDRIA
- SOL-COMBI F.L.
- SOL-COMBI
- SUPER-COMBI